

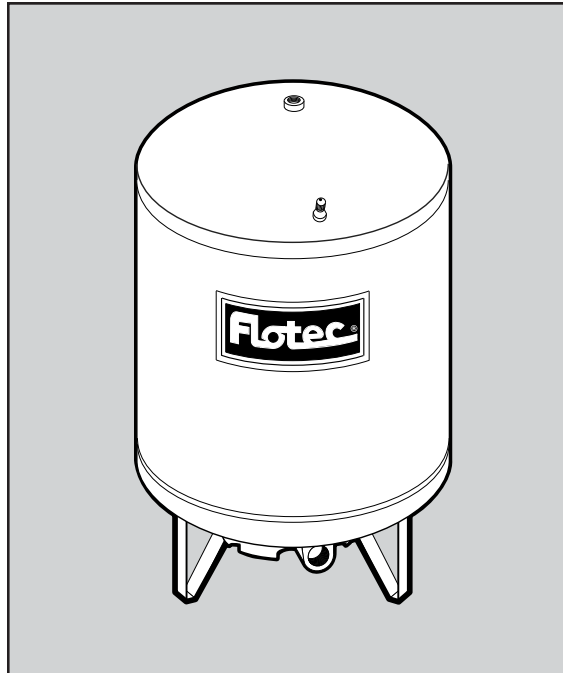

OWNER'S MANUAL
**Pre-Charged Pressure and
Horizontal Tanks and Fittings**

P.O. Box 342, Delavan, WI 53115
Phone: 1-800-365-6832
Fax: 1-800-526-3757
E-Mail: info@flotecwater.com
Web Site: <http://www.flotecwater.com>

Water
is Our
Business®



MODELS

FP7100

FP7100H

FP7110

FP7110T

FP7110TH

FP7120

FP7125

FP7130

FP7135

Installation/Operation/Parts

*For further operating,
installation, or maintenance
assistance:*

Call 1-800-365-6832

English..... Pages 2-8

READ AND FOLLOW SAFETY INSTRUCTIONS!

 **This is the safety alert symbol.** When you see this symbol on your pump or in this manual, look for one of the following signal words and be alert to the potential for personal injury.

 **DANGER** warns about hazards that **will** cause serious personal injury, death or major property damage if ignored.

 **WARNING** warns about hazards that **can** cause serious personal injury, death or major property damage if ignored.

 **CAUTION** warns about hazards that **will** or **can** cause minor personal injury or property damage if ignored.

The label **NOTICE** indicates special instructions which are important but not related to hazards.

Carefully read and follow all safety instructions in this manual and on pump.

Keep safety labels in good condition.

Replace missing or damaged safety labels.

1. Read this manual carefully. Failure to follow these Instructions could cause serious bodily injury and/or property damage.
2. Consult installer or licensed plumber for correct relief valve. Install system according to local codes.
3. Always test water from well for purity before using. Check local health department for testing procedure.
4. Before installing or servicing tank, BE SURE pump electric power source is disconnected. Release all water pressure before working on tank or system. Release air pressure before removing cover flange.
5. Install relief valve in pump supply line to tank, as close to tank as possible.
6. BE SURE pump electrical circuit is properly grounded.
7. Remove bleeder orifices, air volume controls or other air charging devices in existing system.
8. DO NOT USE tank as a surge suppressor.

 **WARNING** Hazardous pressure. To prevent possible serious or fatal injury and/or damage to equipment, system pressure must be less than 100 pounds per square inch (PSI) (689kPa) under any circumstances. Failure to follow instruction can result in tank blowup. If system discharge pressure can exceed 100 PSI (689kPa), install a relief valve capable of passing the full pump volume at 100 PSI (689kPa).

 **WARNING** Do not allow pump, tank, or piping system to freeze. Freezing can severely damage equipment and may lead to tank explosion and serious injury. Allowing tank to freeze voids tank warranty.

GENERAL INFORMATION

Tanks listed below are pre-charged, or filled with air at the factory, to 40 pounds per square inch (PSI) (276kPa). When installing tank, set tank pressure according to Chart 1. To do this, bleed air from or add air to tank through valve on top of tank.

NOTICE: Always set or check tank pre-charge with NO WATER in tank or water pressure in system. If you have already pumped water before setting or checking pre-charge pressure, turn pump off. Open faucet until there is no more water pressure. Set pre-charge in tank according to Chart 1, then close faucet and turn pump back on.

NOTICE: Replace and tighten air valve cap after pressure is adjusted correctly. Failure to replace air cap may allow loss of air pressure and lead to tank waterlogging and bladder failure.

CHART 1

When Pressure Switch Setting Is	Reduce Tank Precharge (PSI) To
20-40 PSI (138-276 kPa)	18 (124 kPa)
30-50 PSI (207-345 kPa)	28 (193 kPa)
40-60 PSI (276-414 kPa)	38 (262 kPa)

(The first number on the pressure switch is the pump on setting; the second number is the pump off setting.)

Pre-charged storage tanks can be connected together to increase the drawdown. Drawdown is the actual amount of usable water available from when the tank is full to when the pump turns on. Installing two tanks of same size will double the drawdown supply, three tanks will triple the drawdown supply, (Figure 1). Locate pressure switch as shown. Tank and pressure switch cannot be more than 10' (3M) apart.

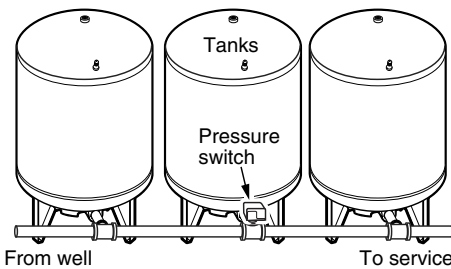

Figure 1

NOTICE: Tank capacity is different than drawdown. Tank capacity is the actual physical volume of the sheet metal that makes up the tank.

OPERATING CYCLE (FIGURE 2)

- Step 1. Tank nearly empty – air expands filling area above bladder (Figure A).
- Step 2. Water enters tank – air is compressed above bladder as it fills with water (Figure B).
- Step 3. Pump-up cycle completed – air compressed to OFF setting of pressure switch (Figure C).
- Step 4. Water drawn from tank – compressed tank air forces water out of bladder (Figure D).
- Step 5. Bladder empty – new cycle ready to begin (Figure A).

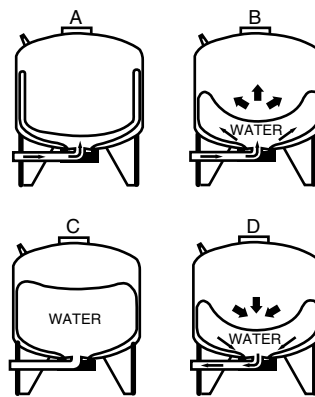

Figure 2

Connect discharge pipe from pump to a tee. Connect one side of tee to tank flange and the other side of tee to service. Use plastic or steel pipe as required. To prevent leaks, use Teflon tape or Plasto-Joint Stik¹ on male threads of all threaded connections to tank.

STANDARD TANK REPLACEMENT

When replacing standard tank in a water system with pre-charged tank, no bleeder orifices or Air Volume Control (AVC) are required. When sizing a pre-charged tank to replace a standard tank, the tanks should have equivalent drawdowns. For example, model FP7110T precharged tank has a drawdown of 5.8 gallons (22L) and is equivalent to a 42 gallon standard tank that has a drawdown of 4.3 gallons (16.3L).

▲WARNING Hazardous voltage and hazardous pressure. Disconnect all power to pump and bleed all pressure from system before working on pump, tank, or piping.

¹Lake Chemical Co., Chicago, Illinois

For jet pump installation, remove AVC tube from port in pump body or jet body and plug port (see Figure 3). New pumps come with plug installed.

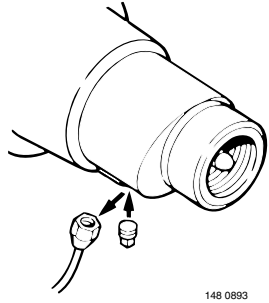

Figure 3: Plug AVC Port when installing pre-charged tank on existing pumps. New pumps come with plug installed.

NOTICE: When working on submersible pumps in wells be sure safety rope is solidly connected to pump and to secure anchor at the well head at all times. **Do not drop the pump down the well!**

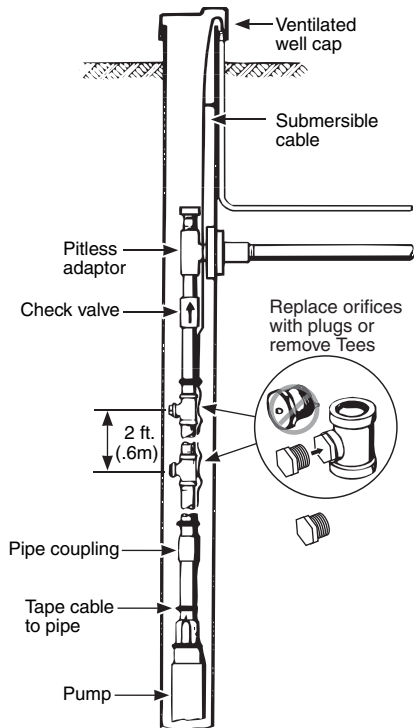

Figure 4

NOTICE: For submersible pump installations, there may be bleeder orifices in the vertical discharge pipe. They must be removed and the tees plugged when a pre-charged tank is installed in the system. To do this, raise the pump and discharge piping enough to bring the bleeder orifices clear of the well. Remove the bleeder orifices from tees and replace with plugs (see Figure 4). Bleeder orifices may be any of several sizes. Have a pair each of 1/2", 3/4", and 1" plugs available. Replace pump and reconnect the discharge pipe.

NOTICE: To be sure joint is not cross-threaded and threads are clean, make connections by hand (without sealer) first. When threads are clean, remove pipe, add Teflon tape or Plasto-Joint Stik, and remake connection. Tighten by hand first; finish with pipe wrench.

In areas where temperature is high for long periods of time, tank pre-charge pressure may increase. This may reduce tank drawdown (amount of water available per cycle). If this occurs, adjust pre-charge pressure according to Chart 1, page 3.

Flush all air out of piping system and water reservoir portion of pre-charged tank. Required on: new installations, pumps requiring repriming, and pumps disassembled for service. Do as follows:

- Step 1. Open faucets furthest from tank and run pump.
- Step 2. Run pump until sputtering stops and steady stream of water flows.
- Step 3. Open and close faucets repeatedly until all air has been removed.
- Step 4. If stream does not become steady, air may be leaking into system; check for leaks in piping on suction side of pump.

NOTICE: To prevent waterlogging, check tank air charge annually.

TO CHECK TANK AIR CHARGE

If drawdown decreases significantly, check as follows:

- Step 1. To check air charge in tank, shut off electric power to pump, open faucet near tank, and drain completely.
- Step 2. At air valve, check tank air pressure with tire gauge. See Chart 1, page 3, for correct pressure setting. If needed, adjust tank pressure up or down.
- Step 3. Use soap or liquid detergent to check for air leaks around air valve. Continuous bubbling indicates leak. If necessary, release air pressure and install new core in air valve, (same as used for automobile tubeless tires.)

TESTING FOR BLADDER LEAKAGE

- Step 1. **Disconnect power to pump.**
- Step 2. Drain water from tank bladder by opening faucet closest to tank.
- Step 3. Remove valve cap and release all pressure by depressing valve core. When air stops coming from valve, remove valve core to release remaining pressure.
- Step 4. Disconnect piping from elbow on tank cover flange.
- Step 5. Carefully turn tank upside down or lay on its side.

- ⚠ WARNING** Retained water in tank may cause sudden weight shift when lowering. Support tank so it cannot fall when being lowered or inverted.
- Step 6. If bladder leaks, water will run out of valve. If so, replace bladder.
- Step 7. If replacing bladder, be sure air and water pressures are relieved before removing cover flange. When reassembling cover flange, do not tighten nuts or mounting studs more than 85 in-lbs. (9.6 Nm).

NOTICE: When using metal pipe with plastic fittings use only Teflon tape or Plasto-Joint Stik' on male threads.

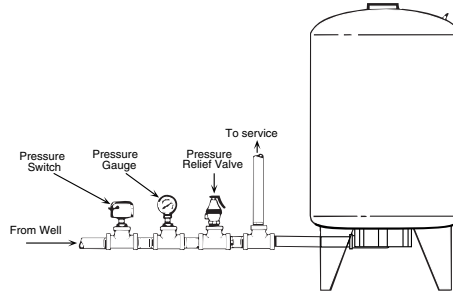

160 0893

Figure 5: Typical installation with vertical pre-charge tank and submersible well pumps

NOTICE: Most standard tanks have separate inlet and outlet ports. Pre-charge tanks have one port serving both functions. When replacing standard tank with a pre-charge tank, run pipe from pump into a tee as shown. 2nd leg of tee goes to tank elbow; 3rd leg goes to existing service.

Product Information – Pre-Charged Tanks

Catalog Number	Drawdown - Gals (L)		
	20-40 PSI (138-276kPa)	30-50 PSI (207-345kPa)	40-60 PSI (276-414kPa)
FP7100	2.2 (8.3)	1.8 (6.8)	1.6 (6.1)
FP7100H	2.2 (8.3)	1.8 (6.8)	1.6 (6.1)
FP7110T	6.9 (26.1)	5.8 (22)	5.0 (18.9)
FP7110TH	6.9 (26.1)	5.8 (22)	5.0 (18.9)
FP7110	6.9 (26.1)	5.8 (22)	5.0 (18.9)
FP7120	12.7 (48.1)	10.7 (40.5)	9.3 (35.2)
FP7125	18.3 (69.3)	15.5 (58.7)	13.4 (50.7)
FP7130	30.0 (113.6)	26.0 (98.4)	22.0 (83.3)
FP7135	41.3 (156.3)	35.4 (134.0)	31.0 (117.3)

Catalog Number	Maximum Capacity US Gals (L)	Equivalent to Standard Tank US Gals (L)	Tank Diameter (mm)	Tank Height (mm)	Tank Discharge Tapping
FP7100	6 (23)	15 (57)	12" (305)	*16-1/2" (419)	3/4"
FP7100H	6 (23)	15 (57)	12" (305)	*16-1/2" (419)	3/4"
FP7110T	19 (72)	42 (159)	16" (406)	30-1/8" (765)	1"
FP7110TH	19 (72)	42 (159)	16" (406)	*24-5/8" (625)	1"
FP7110	19 (72)	42 (159)	20" (508)	22-3/4" (578)	1"
FP7120	35 (132)	82 (310)	20" (508)	36-1/4" (921)	1"
FP7125	50 (189)	120 (454)	24" (610)	34-3/4" (883)	1-1/4"
FP7130	85 (322)	220 (833)	24" (610)	54" (1372)	1-1/4"
FP7135	119 (450)	320 (1211)	24" (610)	68" (1727)	1-1/4"

* Length overall; this model is a horizontal tank.

For parts or assistance, call Flotec Customer Service at 1-800-365-6832

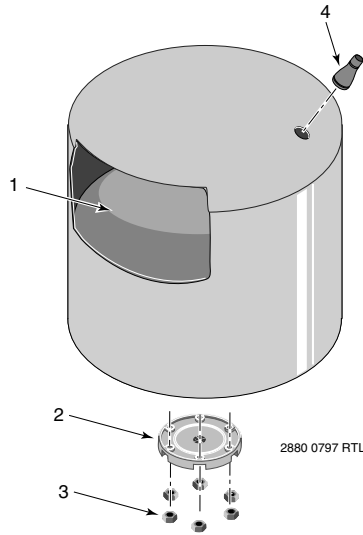

Model
FP7100-08

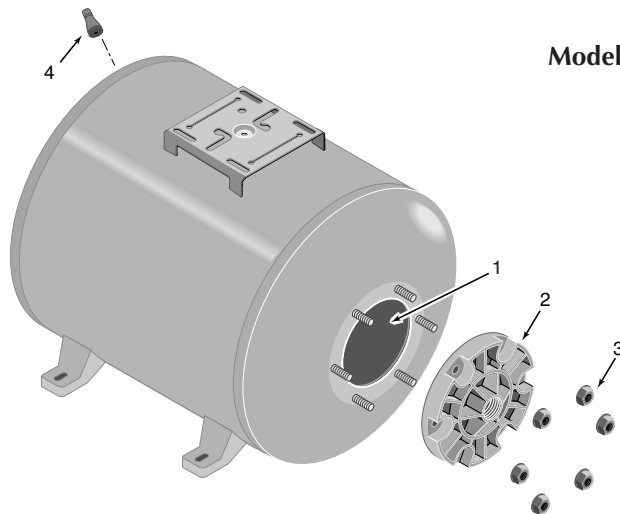

Model FP7100H-08

REPAIR PARTS LIST

Key No.	Part Description	No. Used	FP7100H-08	FP7100-08
1	Bladder - Vinyl	1	U20-7	U20-7
2	Cover Flange	1	U31-442P	U31-442P
3†	Flanged Nut - 5/16 - 18 Hex.	6	U36-202BT	U36-202BT
4	Air Valve with Cap	1	U212-160	U212-160

† Standard hardware items, may be purchased locally.

For parts or assistance, call Flotec Customer Service at 1-800-365-6832

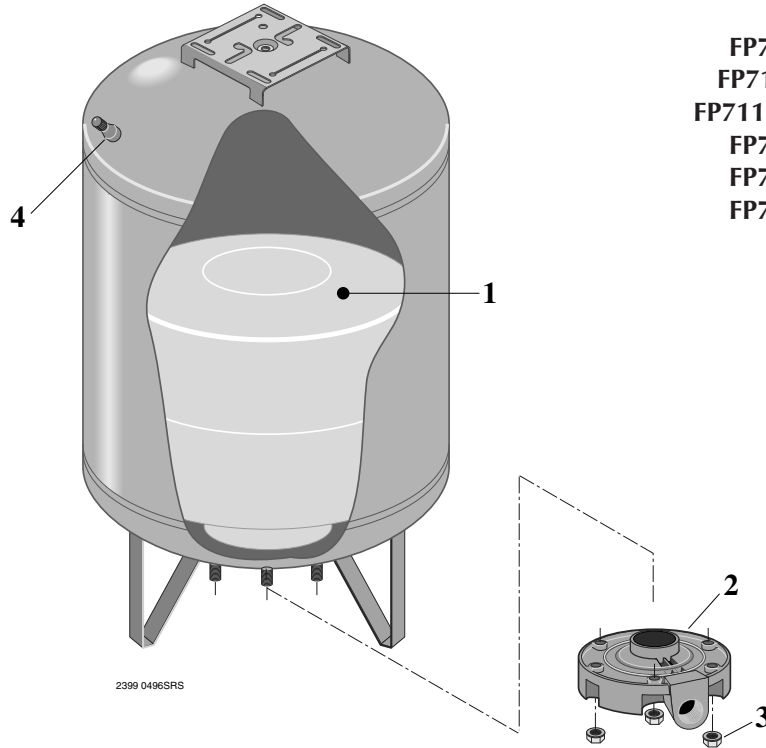

Models
 FP7110-08
 FP7110T-08
 FP7110TH-08
 FP7120-08
 FP7125-08
 FP7130-08
 FP7135

REPAIR PARTS LIST

Key No.	Part Description	No. Used	FP7110-08	FP7110T-08	FP7110TH-08
1	Bladder - Vinyl	1	U20-8	U20-13	U20-13
2	Cover Flange and Elbow	1	U31-446P	U31-446P	U31-446P
3	Flanged Nut - 5/16 - 18 Hex	6	U36-202BT	U36-202BT	U36-202BT
4	Air Valve with Cap	1	U212-160	U212-160	U212-160

Key No.	Part Description	No. Used	FP7120-08	FP7125-08	FP7130-08
1	Bladder - Vinyl	1	U20-9	U20-10	U20-14
2	Cover Flange	1	U31-446P	U31-447P	U31-447P
3	Flanged Nut - 5/16 - 18 Hex	6	U36-202BT	U36-202BT	U36-202BT
4	Air Valve with Cap	1	U212-160	U212-160	U212-160

Key No.	Part Description	No. Used	FP7135
1	Bladder - Vinyl	1	U20-20
2	Cover Flange	1	U231-462P
3	Flanged Nut - 5/16 - 18 Hex	6	U36-202BT
4	Air Valve with Cap	1	U212-160

For parts or assistance, call Flotec Customer Service at 1-800-365-6832

ATTACH ORIGINAL RECEIPT HERE FOR WARRANTY CONSIDERATION.

FLOTEC warrants to the original consumer purchaser ("Purchaser") of its products that they are free from defects in material or workmanship.

If within twelve (12) months from the date of the original consumer purchase any such product shall prove to be defective, it shall be repaired or replaced at FLOTEC's option, subject to the terms and conditions set forth below. Your original receipt of purchase is required to determine warranty eligibility.

Exceptions to the Twelve (12) Month Warranty

Product	Warranty Period
Drill Pump, Pitcher Pump, In-line Water Filter Cartridge	90 days
1/3 HP Submersible Sump Pumps INTELLIPUMP (Model FP0S1775A) Back-up Sump Pump System (Model FP2800DCC)	2 Years
4" Submersible Well Pumps 1/2 HP Submersible Sump Pumps Models FPSC2200A-10 and FPSC2250A-10	3 Years
Pre-Charge Water System Tank Models FPSC3200A-10 and FPSC3250A-10	5 Years
Floodmate® 7000 (Model FP0S6000A) Ironmate® (Model FPSC4550A) Sewage Ejector (Model FPSE3601A) Pedestal Sump Pump (Model FPPSS5000) Utility Pump (Model FPSC1725X) Submersible Sump Pump (Model FPSC4550A-10)	Lifetime

General Terms and Conditions

Purchaser must pay all labor and shipping charges necessary to replace product covered by this warranty. This warranty shall not apply to acts of God, nor shall it apply to products which, in the sole judgement of FLOTEC, have been subject to negligence, abuse, accident, misapplication, tampering, alteration; nor due to improper installation, operation, maintenance or storage; nor to other than normal application, use or service, including but not limited to, operational failures caused by corrosion, rust or other foreign materials in the system, or operation at pressures in excess of recommended maximums.

Requests for service under this warranty shall be made by returning the defective product to the Retail outlet or to FLOTEC as soon as possible after the discovery of any alleged defect. FLOTEC will subsequently take corrective action as promptly as reasonably possible. No requests for service under this warranty will be accepted if received more than 30 days after the term of the warranty.

This warranty sets forth FLOTEC's sole obligation and purchaser's exclusive remedy for defective products.

FLOTEC SHALL NOT BE LIABLE FOR ANY CONSEQUENTIAL, INCIDENTAL, OR CONTINGENT DAMAGES WHATSOEVER.

THE FOREGOING WARRANTIES ARE EXCLUSIVE AND IN LIEU OF ALL OTHER EXPRESS WARRANTIES. IMPLIED WARRANTIES, INCLUDING BUT NOT LIMITED TO THE IMPLIED WARRANTIES OF MERCHANTABILITY AND FITNESS FOR A PARTICULAR PURPOSE, SHALL NOT EXTEND BEYOND THE DURATION OF THE APPLICABLE EXPRESS WARRANTIES PROVIDED HEREIN.

Some states do not allow the exclusion or limitation of incidental or consequential damages or limitations on how long an implied warranty lasts, so the above limitations or exclusions may not apply to you. This warranty gives you specific legal rights and you may also have other rights which vary from state to state.

FLOTEC • P.O. Box 342 • Delavan, WI U.S.A. 53115

Phone: 1-800-365-6832 • Fax: 1-800-526-3757

E-Mail: info@flotecwater.com • Web Site: <http://www.flotecwater.com>

For parts or assistance, call Flotec Customer Service at 1-800-365-6832