

commercial food waste disposers



The most trusted name in food waste management

**IN
SINK
ERATOR®**



system com

commercial food waste disposer systems

In-Sink-Erator® invented the food waste disposer in 1937. And we've continued to innovate and add system capabilities. Today, we're the number one choice in disposer systems for commercial foodservice.

Power and Performance

We're the recognized leader in disposer quality and reliability. And that means you can count on us for superior performance, quiet operation, maximum energy efficiency and long service life.

Choice of Capacities

We offer four sizes, including 11 different models, from our light-duty LC-50 for delis, convenience stores and fast-food operations to our large capacity 10 HP workhorse model.

Packaged to Match Your Needs

To complete your In-Sink-Erator commercial disposer package, select from an extensive offering of controls and accessories. Choose a switch or control center and a sink or trough mounting or bowl sink assembly. And for water usage reduction, select an Aqua-Saver System, available as an accessory or control center.

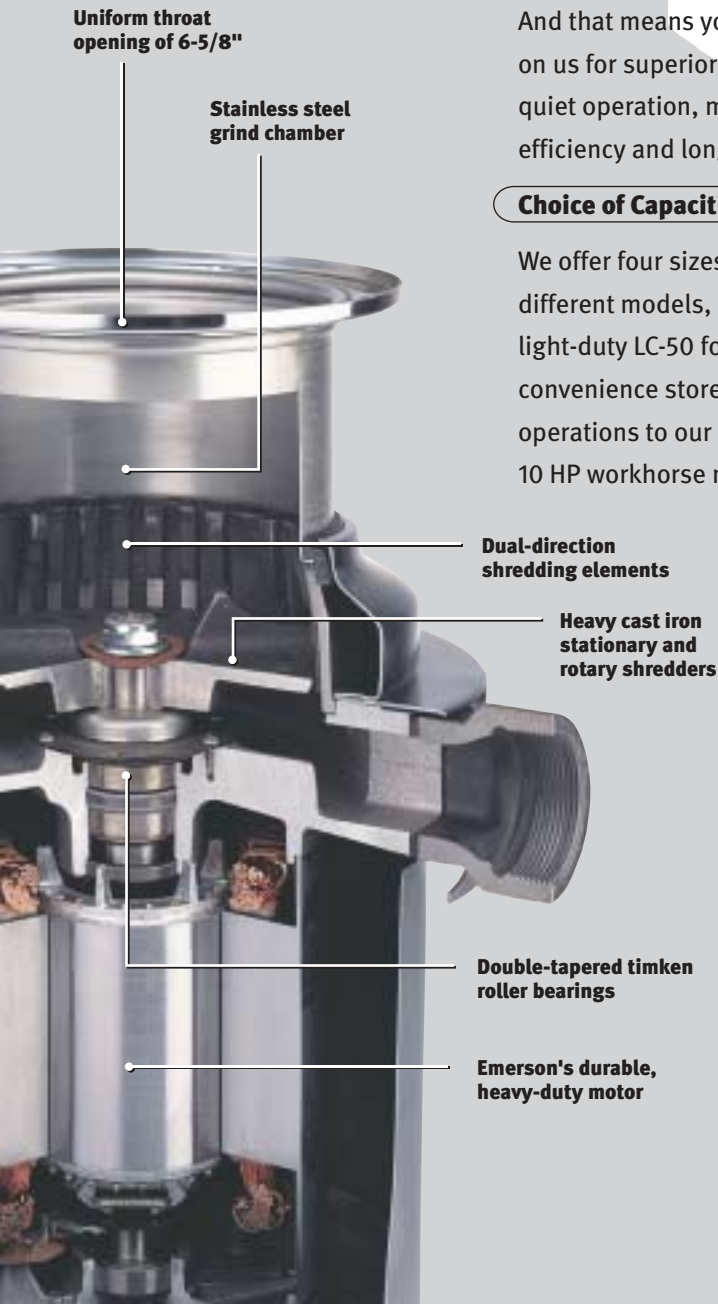

Light duty
LC-50

Small capacity
SS-50
SS-75
SS-100
SS-125

Medium capacity
SS-150
SS-200

Large capacity
SS-300
SS-500
SS-750
SS-1000

Components work together for efficiency and flexibility

Switches and Control Centers



Control Centers Provide Automated Operation

Keep your food waste disposer running smoothly with our selection of switches and control centers. Includes everything from a simple on-off switch to multi-function automatic control centers with reversing features, plus a time delay relay, that allows water to continue running after the disposer is turned off.

Aqua-Saver™ Systems



Aqua-Saver cuts water usage 70% or more

The automatic, on-demand water-saving system lets the right amount of water flow through to flush waste away. When the disposer is idle, water flow is cut to the minimum saving thousands of gallons of water per day. For example, over a 3 year period, cities like San Francisco, Boston and Orlando have saved from \$5,000 – 10,000 using the Aqua Saver system*.

*Based on a 2002 study by Raftelis Financial Consulting

Sink & Trough Mountings



Mounting Adaptors and Bowl Assemblies Fit Any Size Sink

In-Sink-Erator disposers can be installed in any size sink opening and include two types of stainless steel collar adaptors and a sink flange type of adaptor. Or to custom design your disposer and clean up operation, choose from a variety of bowl sink assemblies specially designed for dish tables or drainboards.

Bowl Sink Assemblies

* All type assemblies come in 12", 15" or 18" diameters.



Special controls insure water flow

We offer a syphon breaker that prevents any backflow of water from syphoning back into the water line. A solenoid valve is activated when the water is switched on to insure water is running through the disposer and a flow control valve automatically provides the correct amount of water for efficient disposer operation.

Water Controls



sizing chart

Persons per Meal	Soiled Dish Table	Vegetable Prep Area	Salad Prep Area	Pot Sink	Meat/Seafood Prep Area
Up to 100	SS-75	SS-50	—	—	—
100-150	SS-100	SS-75	SS-50	SS-50	—
150-175	SS-125	SS-100	SS-75	SS-50	SS-150
175-200	SS-150	SS-150	SS-75	SS-75	SS-150
200-300	SS-200	SS-150	SS-75	SS-75	SS-300
300-750	SS-300	SS-150	SS-75	SS-75	SS-300
750-1500	SS-500	SS-300	SS-150	SS-150	SS-500
1500-2500	(2) SS-500	SS-300	SS-150	SS-150	SS-500

2500-over

Contact your food service consultant or In-Sink-Erator

A trusted name

For overall quality, service and reliability, In-Sink-Erator has been the number one choice of food service consultants and equipment dealers for over 17 consecutive years.*

Our long-life construction, performance and dependability make In-Sink-Erator America's best-selling food waste disposer.

*Cahner's Research

Count on the industry's most complete service network.

You're assured of prompt, expert service from over 300 factory-authorized In-Sink-Erator service centers nationwide.

One-year on-site warranty on parts and labor.

For more information, call toll free 1.800.845.8345 or visit our website www.insinkerator.com

suggested installation

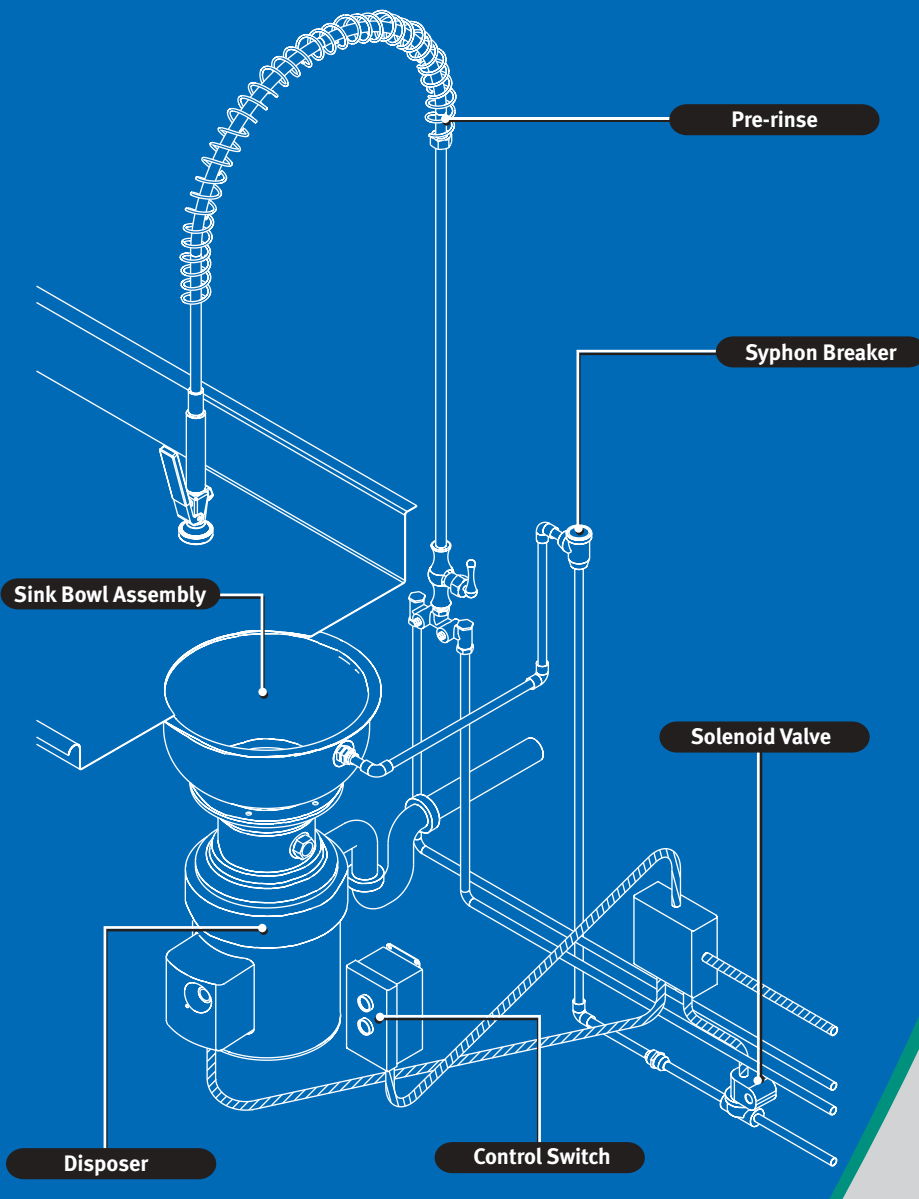

EMERSON
Appliance Solutions

**IN
SINK
ERATOR®**