

comfort™ seats

where quality and comfort meet™

Residential



Seat shall be Comfort Seats **Model Number C2200**

- Premium residential elongated closed front ring design with cover
- Injection molded durable polypropylene plastic UV protection
- Molded in bumpers
- Matching adjustable hinge
- Corrosion proof nuts, bolts and washers
- Rubberized non-skid pads
- Top mount design
- Accepts steel (C200HPM) and 304 stainless (C200HPSS) hardware
- Specify white, bone or biscuit



C2200 Profile

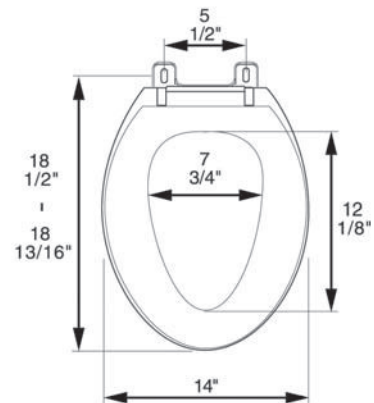

Corrosion proof, self-aligning hardware



Factory-installed "living" hinge covers

Product Specifications

Series: Residential

Model Number: C2200

Seat Type: Elongated -
Closed front with cover

Hinge Design: Heavy duty, large diameter,
molded plastic hinge pivot

Ring Thickness: 5/8"

Ring Thickness with Bumper: 7/8"

Height of Seat with Cover: 1 3/4"

Hardware Options: Stainless Steel (Model #C200-HPSS) or Metal (Model #200-HPM) installation hardware for commercial/hospitality installations. All seats feature UV protection.

comfort™ seats
a Jones Stephens Corp. brand

PHONE: 800-355-6637 (35-JONES)
FAX: 800-462-6991

