

# comfort™ seats

where quality and comfort meet™

Residential



Seat shall be Comfort Seats

## Model Number C014WD Metal Hinge

- Durable molded wood
- Multi-coat high gloss enamel paint
- UV paint color protection
- Elongated closed front with cover
- Varnish coated hinges for added life
- Color matching hinge and bumpers
- Four bumpers on ring for stability
- Non-skid rubberized washer
- Corrosion resistant stainless steel screws
- Corrosion proof hardware
- Specify white, bone, or black
- Specify hinges - brass, chrome, brushed nickel, white powder coat, brass/chrome, white powder coat/chrome



### **C014WD Profile**

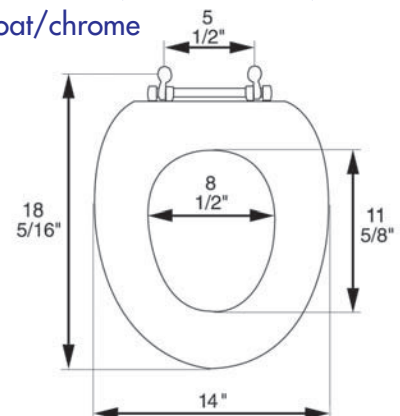

**Chrome**



**White Powder Coat**



**Brass**



**Chrome/White Powder Coat Combo**



**Brushed Nickel**



**Chrome/Brass Combo**

## **Product Specifications**

**Series:** Residential

**Model Number:** C014WD Metal Hinge

**Seat Type:** Elongated -  
Closed front with cover

**Hinge Design:** Chrome, Brass, Brushed Nickel, Chrome / Brass combo, White Powder Coat, Chrome / White Powder Coat Combo

**Ring Thickness:** 3/4"

**Ring Thickness with Bumper:** 1 1/8"

**Height of Seat with Cover:** 2 1/4"

Comfort Seats molded wood utilizes the finest paint to seal and beautify the molded wood core with deep lustrous color and rock hard enamel durability.

**comfort™ seats**  
a Jones Stephens Corp. brand

PHONE: 800-355-6637 (35-JONES)  
FAX: 800-462-6991

