



R E S I D E N T I A L P L A S T I C S E A T S



200TC

Seats shall be No. 200TC as manufactured by Bemis Manufacturing Co. Seats shall be heavy weight and injection molded of solid plastic. Seats shall be closed front with cover for regular bowl and feature large molded-in bumpers. Color matched Top-Tite® hinges contain stainless steel pintles, non-corrosive top-tightening bolts, wing nuts and no-slip washers. The "locked-in" Top-Tite® hinge design will prevent wobbling. The molded-in bumpers provide easy cleaning. Color to be _____. (Specify white or fixture manufacturer's color.)

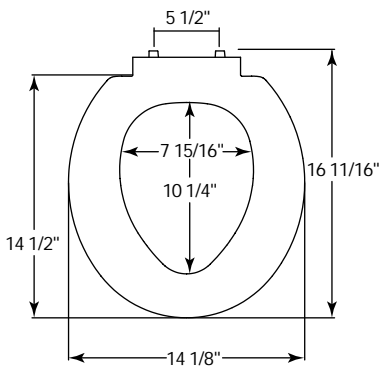

TOP-TITE® HINGES
FEATURE
NO-SLIP WASHER



"LOCKED-IN"
TOP-TITE® HINGE



200TC PROFILE

Ring thickness is 5/8"
Ring thickness including the bumper is 15/16"
Height of the seat with cover is 2-9/32"

