



COMMERCIAL PLASTIC SEATS

1950

Seats shall be No. _____ as manufactured by Bemis Manufacturing Co. Seats shall be heavy weight and injection molded of solid plastic. Seats shall be open front with cover for elongated bowl and feature large molded-in bumpers. Color-matched Top-Tite® hinges contain stainless steel pintles and non-corrosive top-tightening bolt, wing nut and no-slip washer. The "locked-in" Top-Tite® hinge design will prevent wobbling. The molded-in bumpers provide easy cleaning. Color to be white. Hinges shall be _____.

- 1950 Open front seat with cover/Top-Tite® hinges
- 1950SS Open front seat with cover/self-sustaining hinges with 300 Series stainless steel pintles.

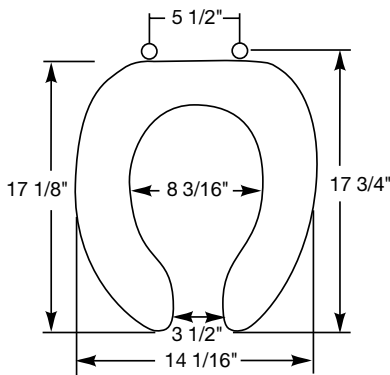

Ring thickness is 3/4"
 Ring thickness including the bumper is 1-1/16"
 Height of the seat with cover is 2-1/4"



**TOP-TITE® HINGES
 FEATURE
 NO-SLIP WASHER**



**"LOCKED-IN"
 TOP-TITE® HINGE**



**300 SERIES STAINLESS
 STEEL SELF-SUSTAINING
 HINGE**

