

Series 919

Reduced Pressure Zone Assemblies

Sizes: ¼" – 2" (8 – 50mm)

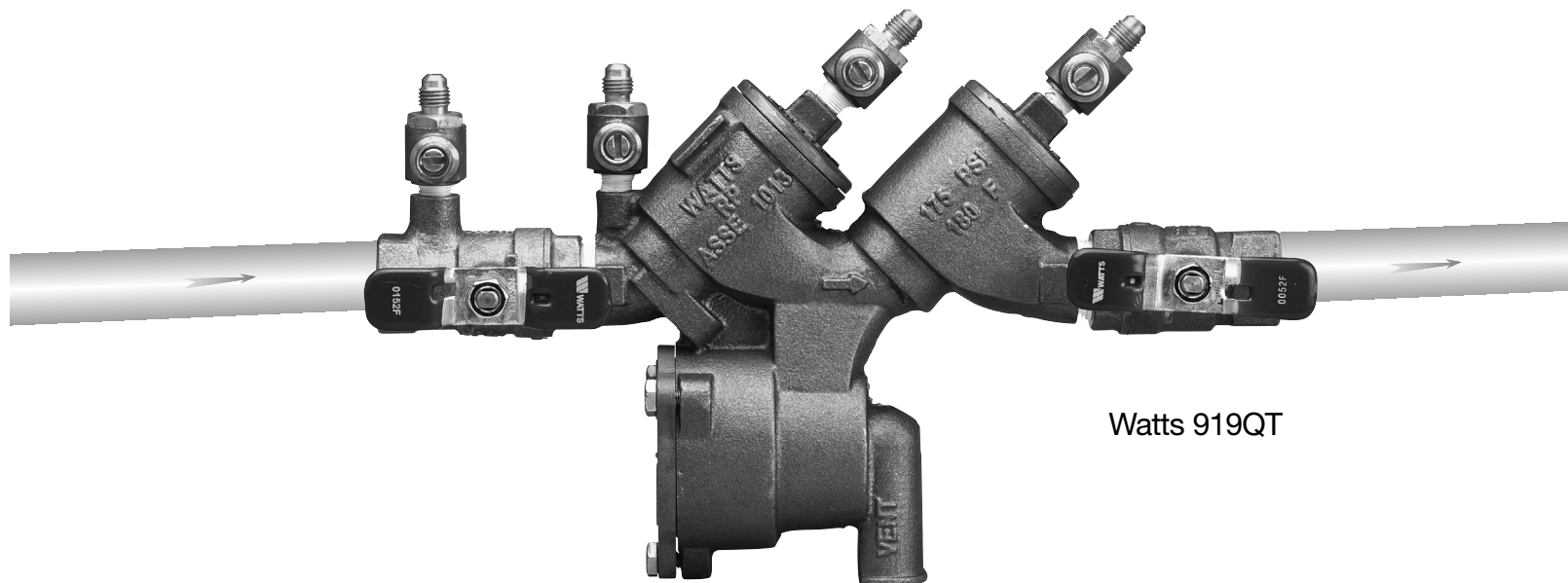

Watts 919QT

- Installation
- Service
- Repair Kits
- Maintenance

For field testing procedure, send for IS-TK-DL, IS-TK-9A, IS-TK-99E and IS-TK-99D.

For other repair kits and service parts, send for PL-RP-BPD.

For technical assistance, contact your local Watts representative on back page.

IMPORTANT: Inquire with governing authorities for local installation requirements.

NOTE: For Australia and New Zealand, line strainers should be installed between the upstream shutoff valve and the inlet of the backflow preventer.

It's important that this assembly be tested periodically in compliance with local codes, but at least once per year or more as service conditions warrant. If installed on a fire sprinkler system, all mechanical checks, such as alarm checks and backflow preventers, should be flow tested and inspected internally in accordance with NFPA 13 and NFPA 25.

CALIFORNIA PROPOSITION 65 WARNING

WARNING: This product contains chemicals known to the State of California to cause cancer and birth defects or other reproductive harm. (California law requires this warning to be given to customers in the State of California.)

For more information: www.watts.com/prop65

Limited Warranty: Watts Regulator Company warrants each product to be free from defects in material and workmanship under normal usage for a period of one year from the date of original shipment. In the event of such defects within the warranty period, the Company will, at its option, replace or recondition the product without charge. This shall constitute the sole and exclusive remedy for breach of warranty, and the Company shall not be responsible for any incidental, special or consequential damages, including without limitation, lost profits or the cost of repairing or replacing other property which is damaged if this product does not work properly, other costs resulting from labor charges, delays, vandalism, negligence, fouling caused by foreign material, damage from adverse water conditions, chemical, or any other circumstances over which the Company has no control. This warranty shall be invalidated by any abuse, misuse, misapplication or improper installation of the product. **THIS WARRANTY IS IN LIEU OF ALL OTHER WARRANTIES, EXPRESS OR IMPLIED, INCLUDING ANY IMPLIED WARRANTIES OF MERCHANTABILITY OR FITNESS FOR A PARTICULAR PURPOSE.** Any implied warranties that are imposed by law are limited in duration to one year.

Some States do not allow limitations on how long an implied warranty lasts, and some States do not allow the exclusion or limitation of incidental or consequential damages. Therefore the above limitations may not apply to you. This Limited Warranty gives you specific legal rights, and you may have other rights that vary from State to State. You should consult applicable state laws to determine your rights.

WATTS®

Basic Installation Instructions 1/4" - 2" (8 - 50mm)

Series 919 Reduced Pressure Zone Assemblies

Indoor Installation

For indoor installations, make sure the Series 919 is easily accessible to facilitate testing and servicing. Do not install in concealed locations. If the location of the Series 919 is parallel and close to the wall, make sure the test cocks are easily accessible, and the drain line can adequately drain if required. An air gap and drain line (see literature ES-AG/EL/TC) are piped from the relief valve connection as shown, allowing evidence of discharge to be clearly visible and preventing the occurrence of water damage.

Indoor Installation

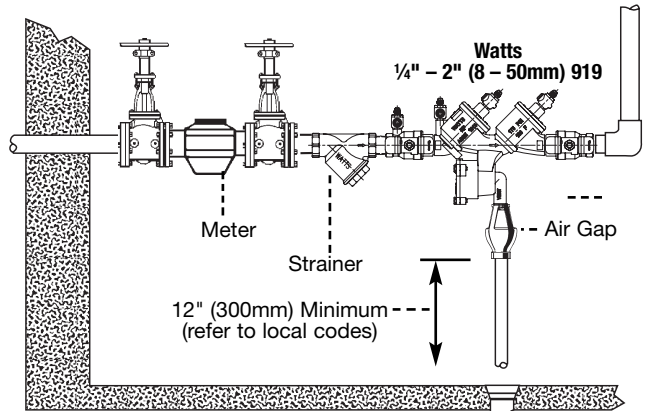

Outdoor, Above Ground Installation

For outdoor installations, it is recommended that you install the Series 919AQT where there are no freezing conditions and above ground whenever possible.

You must install the Series 919 in an accessible location to facilitate testing and servicing. The installation must also allow for adequate drainage from the air gap and the discharge line if needed.

WARNING

1. Do not allow the drain line to empty directly into a drainage ditch, sewer system, or sump.
2. Do not install the Series 919 in any location where any part of the unit could become submerged in standing water.

Outdoor Installation

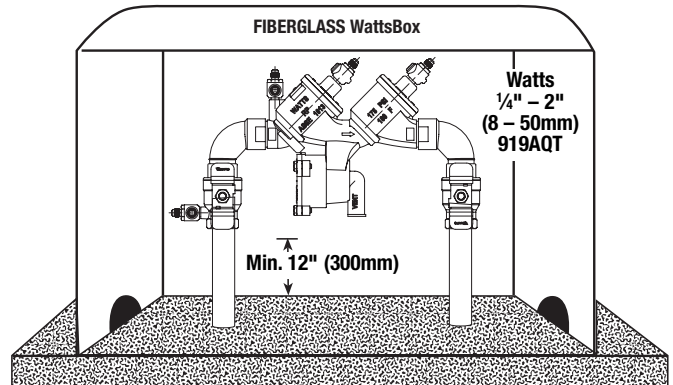

Now available, WattsBox Insulated Enclosures, for more information, send for literature ES-WB.

Parallel Installation

For parallel installations, you can install two or more small sized Series 919's (when approved) to serve a large supply pipe main. You can use this type of installation in an application where increased capacity beyond that provided by a single valve is required. Additionally, this type of installation permits testing and/or servicing of a single valve without shutting down the complete line.

The number of Series 919 units installed in parallel should be determined by the engineer's judgement, based on the operating conditions of a specific application.

NOTE: The total capacity of all the units installed in the application should equal or exceed that required by the system.

Parallel Installation

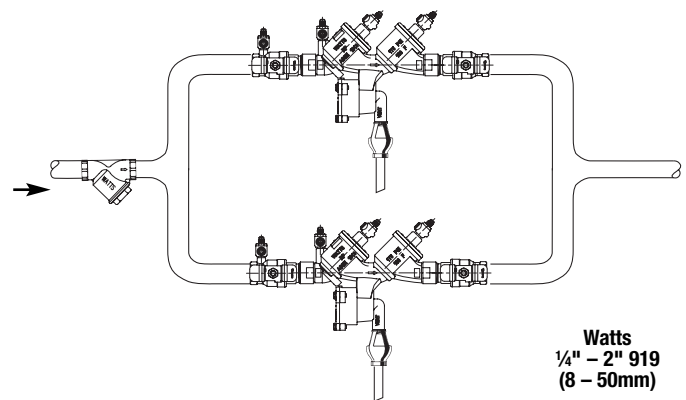

Annual inspection of all water system safety and control valves is required and necessary. Regular inspection, testing and cleaning assures maximum life and proper product function.

Basic Installation Instructions 1/4" – 2" (8 – 50mm)

- A. Shutoff Valves: If you remove the shutoff valves from the Series 919, reassemble the shutoff valve with the test cock mounted on the inlet side of the unit.
- B. Always install the Series 919 in an accessible location to facilitate testing and servicing (See Page 2). *Check the state and local codes to insure that you install the backflow preventer in compliance with those codes, such as the proper height above the ground.
- C. It is recommended that you install a strainer ahead of the Series 919 assemblies to protect the internal components from unnecessary fouling.

CAUTION

Do not install a Series 919 with a strainer in rarely used water lines, such as a fire sprinkler system which is only used during emergencies.

Start Up: Close the downstream shutoff. Open the upstream slowly and fill the valve. When the valve is filled, open the downstream shutoff slowly, and fill the water supply system. This is necessary to avoid water hammer and/or shock damage.

- D. Vent the air gap and drain line from the relief valve in accordance with code requirements. Terminate discharge approximately 12" (300mm) above the ground or through an air gap piped to a floor drain.

WARNING

Do not allow the drain line to empty directly into a drainage ditch, sewer system, or sump.

NOTE: Relief Valve Discharge Rates

The Series 919 air gap and drain line terminating above a floor drain can accommodate any moderate discharge or nuisance spitting through the relief valve. However, to prevent water damage in the case of a catastrophic failure, you may need to design the floor drain size to accommodate the increased discharge. Refer to Figure 1 for maximum relief valve discharge rates, size, and capacity of typical floor drains.

NOTE: DO NOT reduce the size of the drain line from the air gap fitting. The drain line must remain at full line size.

- E. After initial installation of the Series 919, a discharge from the relief valve may occur due to dirt and pipe compounds. This may be due to inadequate initial flushing of the pipe lines. If flushing the valve does not clear the unit, remove the first check valve and clean thoroughly, using the procedures in "Servicing First & Second Check Valves" on page 5.

NOTE: Periodic relief valve discharge may occur on dead end service applications, such as boiler feed lines or cooling tower makeup lines. This may be due to fluctuating supply pressure during a static or no flow condition. To avoid this discharge, install a spring-loaded, rubber seated check valve ahead of the backflow assembly.

F. It is recommended that you not place the Series 919 in a pit or at a depth below the ground level, unless absolutely necessary. If an installation requires below ground level installation, a modified pit installation is recommended, as well as the approval of local codes. In such cases, provision should be made to always vent the drain line above the flood level. In the case of a pit drain, ensure an adequate air gap exists between the bottom of the drain line and the bottom of the pit.

- G. It is recommended that periodic inspection of the Series 919 be done to check for any discharge from the relief valve. This discharge is a visual indication that the valve needs cleaning or repair. In addition, it is recommended that periodic testing of the valve be done in compliance with local codes to ensure its proper operation.

The relief vent discharges water during no-flow periods when:

- (1) the first check valve is fouled; or
- (2) the inlet pressure to the check valve drops sufficiently due to upstream pressure fluctuations. This then affects the required operating differential between the inlet pressure and the reduced pressure zone; or
- (3) the second check is fouled during emergency backflow or resulting from a water hammer condition.

For troubleshooting guide send for literature S-TSG.

NOTE: When installing the Series 919 on fire prevention systems, special considerations are required.

Fire Protection System Installations: The National Fire Protection Agency (NFPA) Guidelines require a confirming flow test be conducted by a certified tester whenever a "main line" valve is installed, such as a shutoff valve or a backflow preventer.

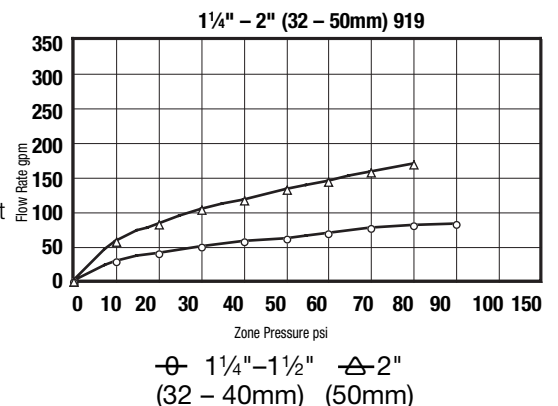
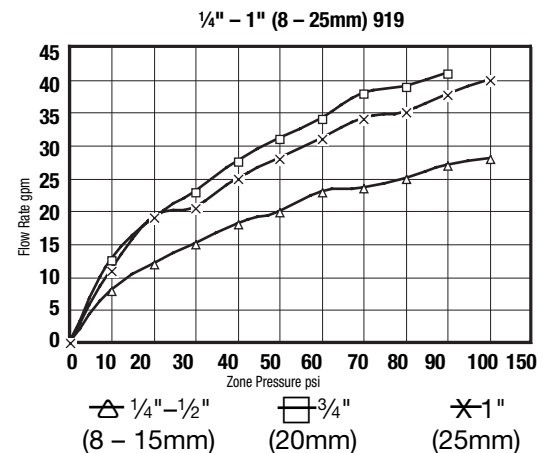
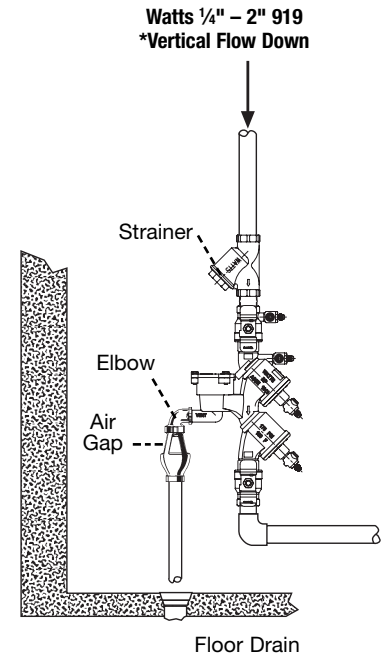

Typical Flow Rates as sized by floor drain manufacturers:

2"	55 GPM	5"	350 GPM
3"	112 GPM	6"	450 GPM
4"	170 GPM	8"	760 GPM

Servicing the Relief Valve 1/4" - 2" (8 - 50mm)

NOTES: 1. No special tools are required to service the Series 919 1/4" - 2".

2. Before servicing, make sure the water is turned off or shutoff valves are closed.

The following procedures provide information for replacing the diaphragm, the relief valve disc, and the relief valve seat. It is recommended that you visually inspect these parts to determine if a replacement or a cleaning is required.

Disassembling the Relief Valve

1. Remove the relief valve cover bolts while holding the cover down.
2. Turn the cover counterclockwise for 1/4 turn, and lift it straight off while still applying pressure to the cover with your hand.

WARNING

Make sure you apply pressure to the cover as you lift it straight off. Due to the release of pressure when removing the cover, the relief valve spring may eject quickly.

3. Remove the relief valve assembly (includes cover O-ring, stem and diaphragm assembly).
4. Remove the relief valve spring.
5. Remove the pressed in relief valve seat and seat O-ring.

Replacing the Diaphragm

6. Using a wrench, loosen the diaphragm assembly by turning the hex bolt counterclockwise.
7. Remove the diaphragm and replace with a new diaphragm if required, or clean the existing diaphragm. The molded step of the diaphragm should point down towards the relief valve stem.
8. Using a wrench, reassemble the diaphragm assembly by turning the hex bolt clockwise to tighten.

Replacing the Relief Valve Disc and Seat

9. Using a phillips screwdriver, remove the screw in the relief valve disc and replace the disc if required, or clean the existing disc.
10. Place the screw back into the relief valve disc and tighten.
11. Replace the relief valve seat with a new seat if required, or clean the existing seat.

Reassembling the Relief Valve

12. Place the relief valve seat back into the chamber bore.
13. Slide the diaphragm assembly into the relief valve seat.
14. Place the spring on to the diaphragm assembly.
15. Place the cover O-ring on the diaphragm assembly.
16. Line up the grooves on the relief valve cover with the grooves in the relief valve body, and turn the cover clockwise 1/4 turn to seat the cover.
17. Using a wrench, place the bolts back into the cover and tighten.

CAUTION

If the cover does not lie flat against the relief valve body, the diaphragm assembly is not installed properly and damage can result. Remove the bolts and cover, realign the diaphragm assembly, and place the cover back on the relief valve body.

18. Open the shutoff valves.

Replacement Parts 1/4" - 2" (8 - 50mm)

When ordering, specify Ordering Code Number, Kit number and Valve Size.

ORDERING CODE	KIT NO.	SIZE	
		in.	mm

Total Relief Valve Kits:

0888130	RK 919 VT	1/4 - 1/2	8 - 15
0888131	RK 919 VT	3/4 - 1	20 - 25
0888132	RK 919 VT	1 1/4 - 2	32 - 50

Kit consists of: Relief Valve Assembly, RV Spring, and RV Cover O-ring

Relief Valve Rubber Parts Kits:

0888135	RK 919 RV	1/4 - 1/2	8 - 15
0888136	RK 919 RV	3/4 - 1	20 - 25
0888137	RK 919 RV	1 1/4 - 2	32 - 50

Kit consists of: Relief Valve Disc, RV Diaphragm, RV Seat O-ring and Cover O-ring

ORDERING CODE	KIT NO.	SIZE	
		in.	mm

Relief Valve Seat Kits:

0888150	RK 919 SV	1/4 - 1/2	8 - 15
0888151	RK 919 SV	3/4 - 1	20 - 25
0888152	RK 919 SV	1 1/4 - 2	32 - 50

Kit consists of: Relief Valve Seat, RV Seat O-ring and RV Cover O-ring

Relief Valve Cover Kits:

888155	RK 919 VC	1/4 - 1/2	8 - 15
888156	RK 919 VC	3/4 - 1	20 - 25
888157	RK 919 VC	1 1/4 - 2	32 - 50

Kit consists of: Relief Valve Cover and Cover O-ring

Air Gaps

0881575	919 AGA	1/4 - 1/2	8 - 15
0881576	919 AGC	3/4 - 1	20 - 25
0881577	919 AGF	1 1/4 - 2	32 - 50

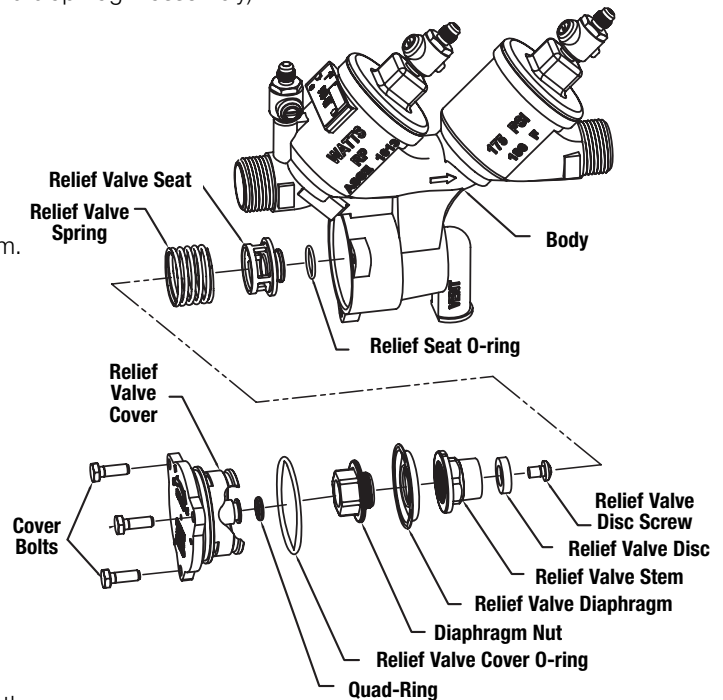

Servicing First & Second Check Valves

1/4" – 2" (8 – 50mm)

NOTES: 1. No special tools are required to service the Series 919 1/4" - 2" (8 – 50).

2. Before servicing, make sure the water is turned off or shutoff valves are closed.

1. Close shutoff valves up and downstream of the valve.
2. Using an appropriate sized wrench, loosen the check valve cover. Unscrew the check valve cover and lift it off.
3. Remove the spring.
4. Lift out the disc holder assembly from the body of the valve.
5. To reverse the seat disc, unscrew the disc screw and disassemble the disc washer and disc rubber from the disc holder assembly. Reverse the disc rubber so the opposite face is showing.
6. Assemble the disc screw through the disc washer and disc rubber, and screw it into the disc holder.
7. To replace the seat module, pull the seat module out of the body by gripping at the reinforcement ring. Replace the seat module with the new seat by placing it into the body seat bore.

NOTE: When you tighten the cover in Step 12, the cover will engage the seat module properly.

8. Insert the disc holder assembly back into the seat module.
9. Replace the spring ensuring that it seats properly on the disc holder.

WARNING

The first check valve has a heavy weight spring. The second check valve has a lighter weight spring. When reassembling the check valves, make sure you install the correct spring into the correct check valve.

10. Place the cover onto the spring with the internal guide on the cover positioned inside the end coil.
11. Screw the cover onto the valve body.
12. Tighten the cover using the appropriate sized wrench.
13. Service the second check valve using Steps 2 through 12.
14. Slowly open shutoff valves.

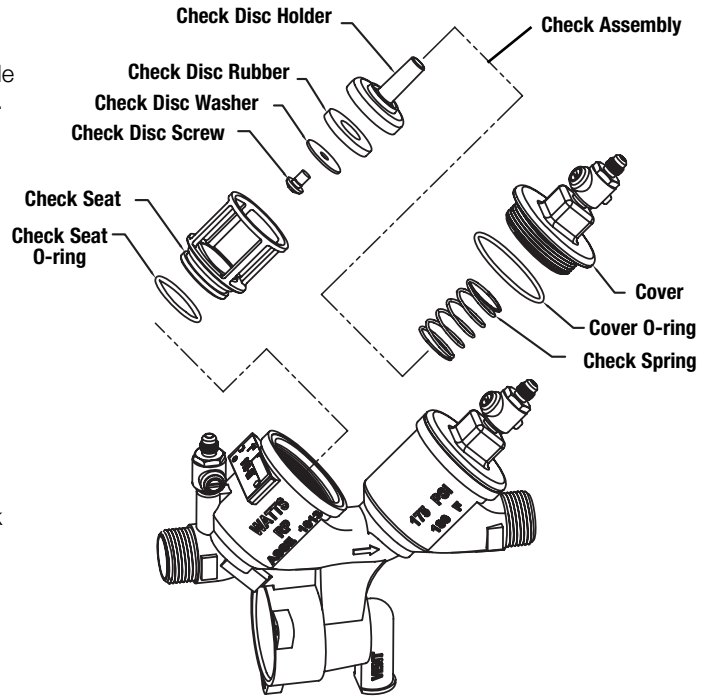

Replacement Parts 1/4" – 2" (8 – 50mm)

When ordering, specify Ordering Code Number, Kit Number and Valve Size.

ORDER CODE	KIT NO.	SIZE	
		in.	mm

1st Check Kits:

0888110	RK 919 CK1	1/4 – 1/2	8 – 15
0888111	RK 919 CK1	3/4	20
0888112	RK 919 CK1	1	25
0888113	RK 919 CK1	1 1/4 – 1 1/2	32 – 40
0888114	RK 919 CK1	2	50

Kit consists of: Check Assembly, Spring and Cover O-ring

2nd Check Kits:

0888115	RK 919 CK2	1/4 – 1/2	8 – 15
0888116	RK 919 CK2	3/4	20
0888117	RK 919 CK2	1	25
0888118	RK 919 CK2	1 1/4 – 1 1/2	32 – 40
0888119	RK 919 CK2	2	50

Kit consists of: Check Assembly, Spring and Cover O-ring

1st or 2nd Check Rubber Parts Kits:

0888120	RK 919 RC4	1/4 – 1/2	8 – 15
0888121	RK 919 RC4	3/4	20
0888122	RK 919 RC4	1	25
0888123	RK 919 RC4	1 1/4 – 1 1/2	32 – 40
0888124	RK 919 RC4	2	50

Kit consists of: Disc, Seat O-ring and Cover O-ring

ORDER CODE	KIT NO.	SIZE	
		in.	mm

Check Seat Kits:

0888125	RK 919 S	1/4 – 1/2	8 – 15
0888126	RK 919 S	3/4	20
0888127	RK 919 S	1	25
0888128	RK 919 S	1 1/4 – 1 1/2	32 – 40
0888129	RK 919 S	2	50

Kit consists of: Seat, Seat O-ring and Cover O-ring

Complete Valve Rubber Parts Kits:

0888140	RK 919 RT	1/4 – 1/2	8 – 15
0888141	RK 919 RT	3/4	20
0888142	RK 919 RT	1	25
0888143	RK 919 RT	1 1/4 – 1 1/2	32 – 40
0888144	RK 919 RT	2	50

Kit consists of: 2 Check Discs, 2 Check Seat O-rings, 1 RV Disc

Check Cover Kits:

0888145	RK 919 C	1/4 – 1/2	8 – 15
0888146	RK 919 C	3/4	20
0888147	RK 919 C	1	25
0888148	RK 919 C	1 1/4 – 1 1/2	32 – 40
0888149	RK 919 C	2	50

Kit consists of: Cover and Cover O-ring

Test Procedures

Reduced Pressure Zone Assemblies must be inspected and tested periodically, in accordance with local codes, to ensure proper operation of check valves within the unit.

A differential pressure gauge is recommended for Test No. 1 rather than a manometer for the following reasons: It utilizes minimum time to perform the test. It eliminates the necessity of closing the inlet ball valve which could release pipe scale and foreign matter into the backflow preventer. Only a slight amount of water is 'spilled' in test. A mercury manometer could cause a pollution hazard.

Test Set Up Reduced Pressure Zone Assembly

Close Valves A, B and C on Test Kit.

Connect high side hose to test cock #2

Connect low side hose to test cock #3. Close shutoff #2.

Open test cocks #2 and #3.

Open vent valve C.

Open 'high' valve A and bleed to atmosphere until all the air is expelled.

Close valve A. Open 'low' valve B and bleed to atmosphere until all air is expelled. Close 'low' valve B. Close 'vent' valve C.

Connect vent hose to test cock #4.

Test Procedure Reduced Pressure Zone Assembly

Field Test Equipment Required

Watts Test Kit

Test No. 1

Purpose: To test Check Valve No. 2 for tightness against reverse flow.

Requirements: Valve must be tight against reverse flow under all pressure differentials. Slowly open the 'high' valve A and the 'vent' valve C, and keep the 'low' valve B closed. Open test cock #4. Indicated pressure differential will decrease slightly. If pressure differential continues to decrease (until the vent opens) check valve #2 is reported as 'leaking'.

Test No. 2

Purpose: To test shutoff #2 for tightness.

Requirements: After passing Test No. 1, continue to Test No. 2 by closing test cock #2. The indicated pressure differential will decrease slightly. If pressure differential continues to decrease (approaching "zero"), shutoff #2 is reported to be "leaking".

Test No. 3

Purpose: To test Check Valve No. 1 for tightness.

Requirements: Valve must be tight against reverse flow under all pressure differentials. Close 'high' valve A and open test cock #2. Close test cock #4. Disconnect vent hose at test cock #4. Open valves B and C, bleeding to atmosphere. Then closing valve B restores the system to a normal static condition. Observe the pressure differential gauge. If there is a decrease in the indicated value, Check Valve No. 1 is reported as "leaking".

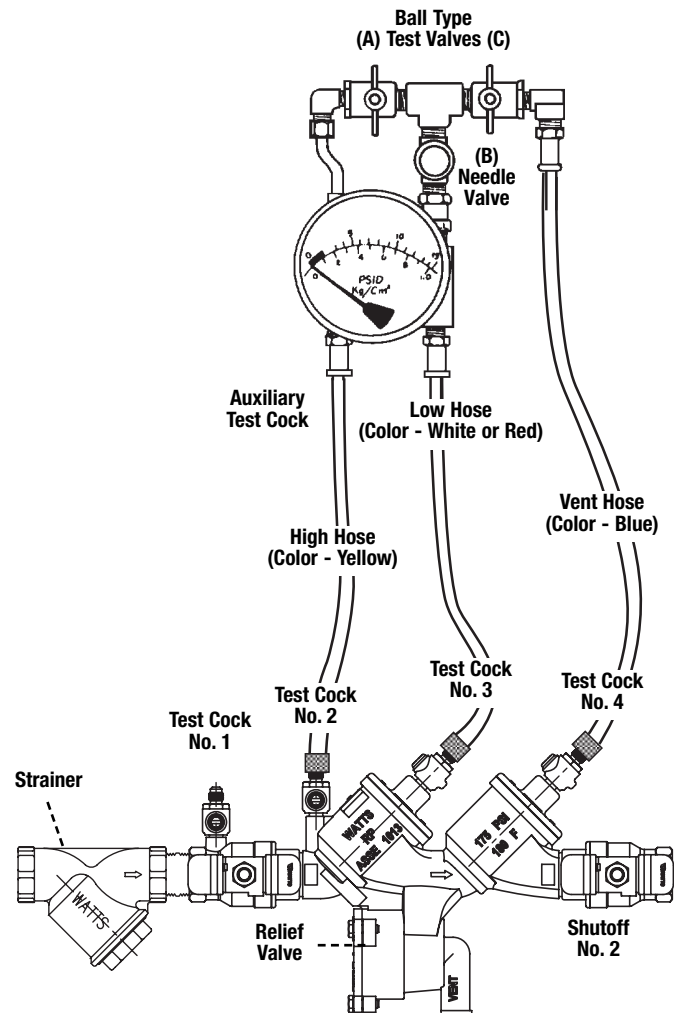

919QTS

Test No. 4

Purpose: To test operation of pressure differential relief valve.

Requirements: The pressure differential relief valve must operate to maintain the "zone" between the two check valves at least 2 psi (14 kPa) less than the supply pressure. Close 'vent' valve C. Open 'high' valve A. Open the 'low' valve B very slowly until the differential gauge needle starts to drop. Hold the valve at this position and observe the gauge reading at the moment the first discharge is noted from the relief valve. Record this as the opening differential pressure of the relief valve.

Note: It is important that the differential gauge needle drops slowly.

Close test cocks #2 and #3. Use 'vent' hose to relieve pressure from test kit by opening valves A, B and C. Remove all test equipment and open shutoff #2.

NOTES

For additional information, visit our web site at: www.watts.com



Water Safety & Flow Control Products



USA: 815 Chestnut St., No. Andover, MA 01845-6098; www.watts.com
Canada: 5435 North Service Rd., Burlington, ONT. L7L 5H7; www.wattscanada.ca